

1966 MODEL 65A GENERATOR BRUSH POSITION CHANGED

The 1966 generator used on Electra Glide and Sportster models has the positions of the positive and negative brush holders reversed so that when the generator is mounted on the motorcycle, the positive brush will be toward the top instead of the bottom. This was done to protect the positive brush holder from accumulated moisture and possible grounding of positive brush holder. The wiring diagrams below show the old and new generator internal wiring connections from field coils to brushes and regulator terminals.

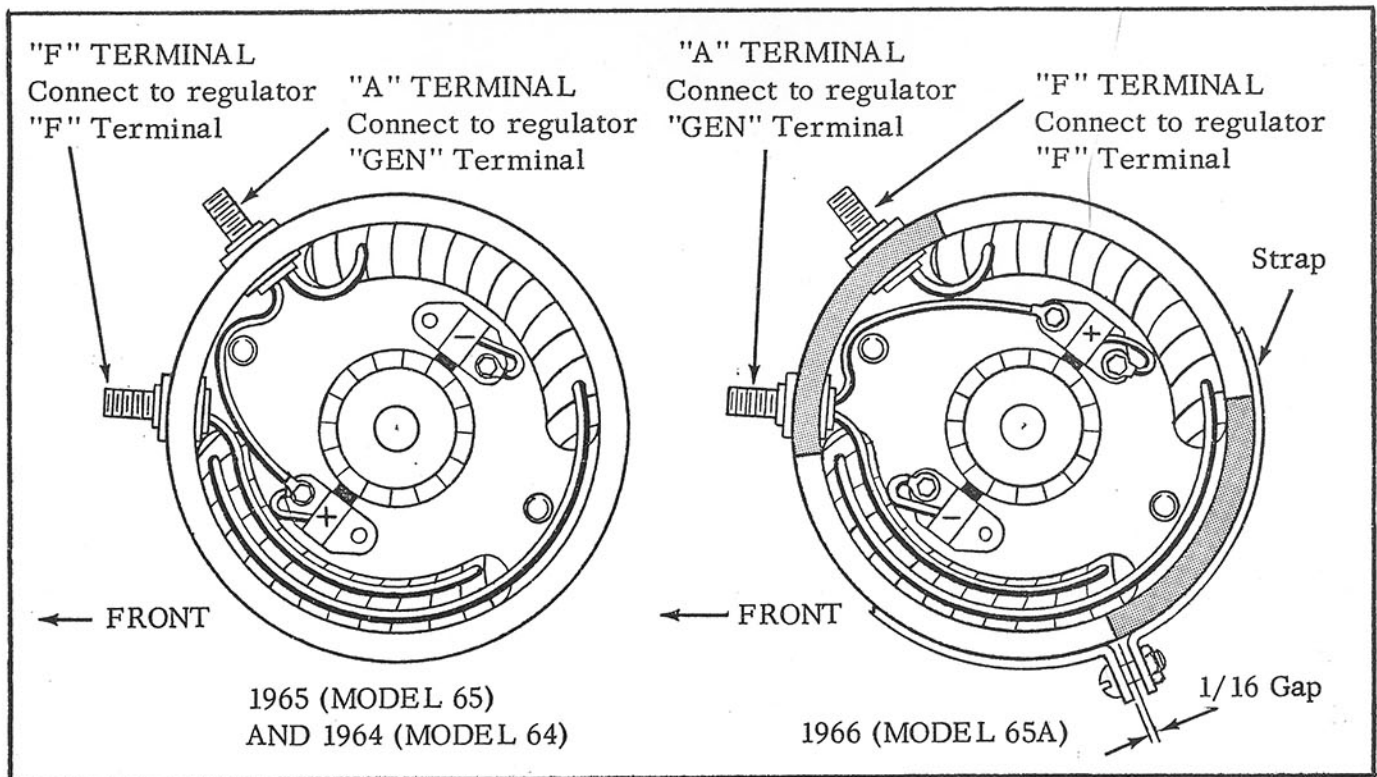

12 VOLT GENERATOR WIRING DIAGRAMS

Note: The front "A" terminal on the 1966 generator is located toward the front of the motorcycle and should be connected to regulator "GEN" terminal (red) wire. Through an oversight, a small number of generators were sent out on early 1966 motorcycles with the terminals "F" and "A" stamped wrong on the generator housing. In this case disregard markings on generator housing. It is advisable to re-stamp any incorrectly marked generators so that they will be correctly wired when serviced in the future.

Important: All 1966 generators have a plastic-coated brush cover strap to protect brush holder and commutator from dirt and water. Strap connection should be located near bottom of generator as shown in diagram so there is a small opening into brush compartment. This will allow any condensation to get out. If necessary, loosen strap and re-position so it screws together in position shown.

HARLEY DAVIDSON MOTOR CO.

Harley-Davidson, Inc. has given us permission to provide this document on our website for the sole purpose of helping us restore our motorcycles.

Harley-Davidson, Inc. retains copyright over these materials, and NO reproduction or other use of these materials is permitted without prior authorization from Harley-Davidson, Inc.

The **Old Sportster and K-model Research Group (OSKRG)** is a group of individuals who have spent years researching the minute differences in the parts, fit, finish, and configuration of the Harley-Davidson 1952-1956 K-Models, and (early) 1957-1969 Sportster models.

The results of our research is published on our website
www.harleyKmodel.com