

### STANDARD CURRENT-VOLTAGE (CIRCUIT "A") REGULATORS

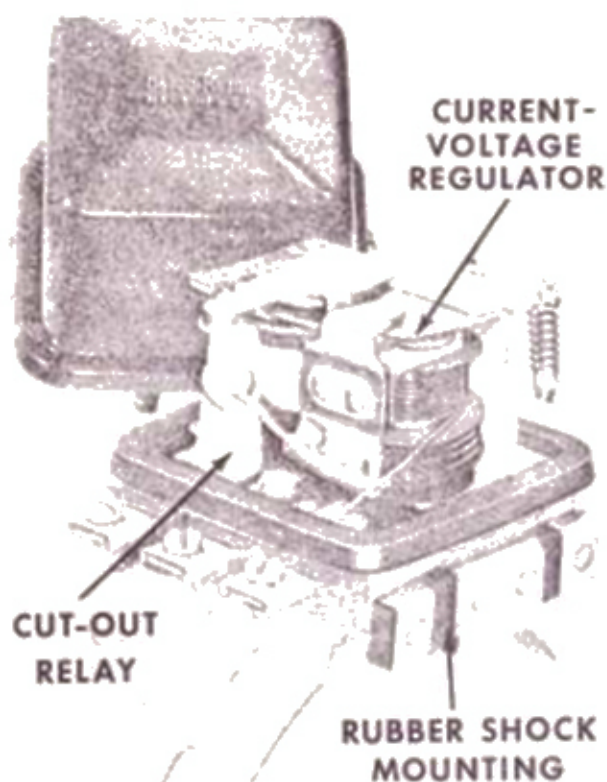

Figure 1—Delco-Remy 1118200 type combined current-voltage regulator with cover removed so units can be seen.

Two designs of Delco-Remy two-unit, combined current-voltage type regulators are shown in Figures 1 and 2. All combined current-voltage type regulators of the 1118200 series are adjusted by bending the spring hangers, while those of the 1118300 and 1118700 type series are equipped for screw adjustment. The covers, which are crimped on during manufacture, have been removed so that the units may be seen. Regulators of this type are used with both third brush and shunt type generators having externally grounded field circuits. However, a special wiring circuit in the regulator adapts it specifically to the type of service encountered in the farm or industrial tractor operation or stationary installations. Although these regulators are similar in appearance and construction to the two-unit standard regulators, the two types are not interchangeable because of this difference in the wiring circuits. Special testing procedures are also required for the combined current-voltage regulators for the same reason.

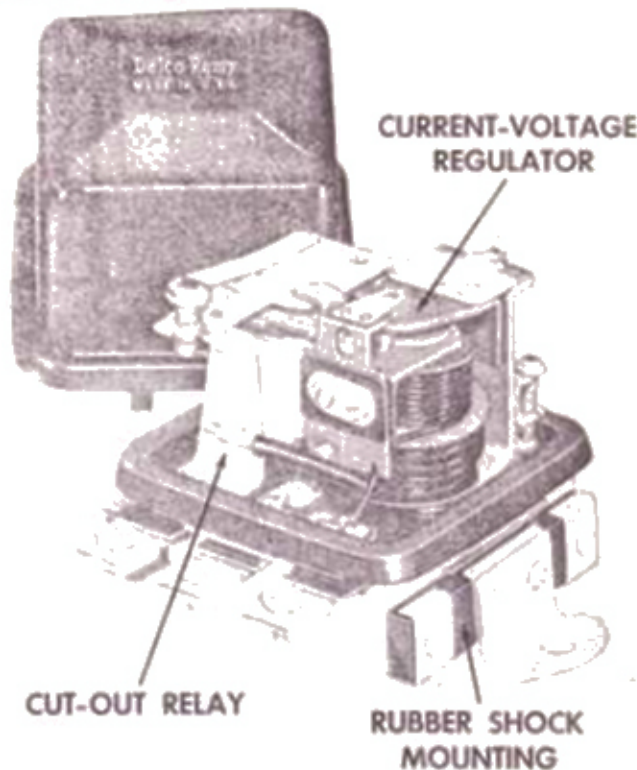

Figure 2—Delco-Remy 1118300 and 1118700 type combined current-voltage regulator with cover removed so units can be seen.

#### CONSTRUCTION

The regulators shown in Figures 1 and 2 consist of two units, a cutout relay and a combination current-voltage regulator. A heavy soft rubber gasket seals the junction between the cover and the regulator base to prevent the entrance of dust and moisture. The cover is crimped on during manufacture and should not be removed for repairs or adjustments except in emergencies. A special rubber shock mounting protects the regulator from shocks and vibration transmitted through the vehicle frame and engine. The wiring circuit of the combined current-voltage regulator is shown in Figure 3.

#### CUTOUT RELAY

The cutout relay is a device which closes the circuit between the generator and the battery when the generator is operating at sufficient speed to charge the battery, and which opens this circuit, when the generator slows down or stops, to prevent the battery from discharging back through the gener-

## STANDARD REGULATORS

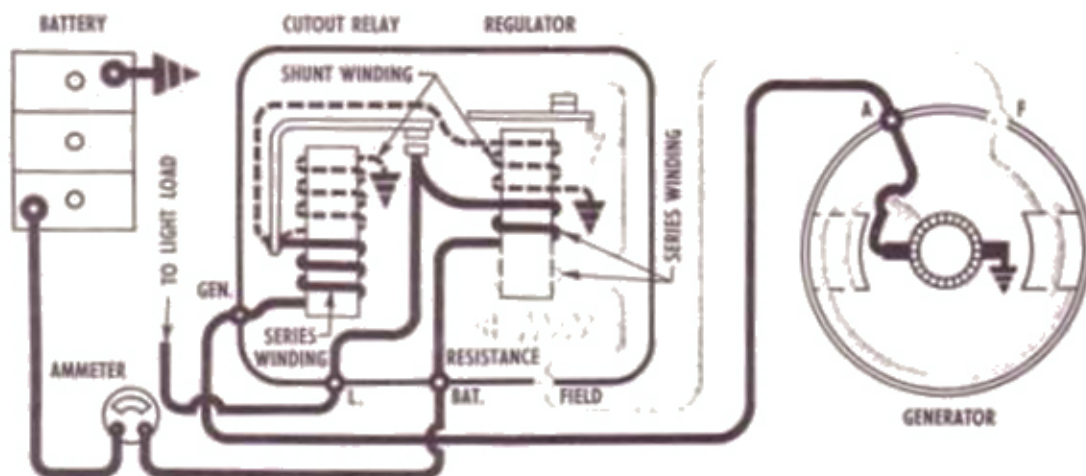

Figure 3—Wiring circuit of Delco-Remy combined current-voltage regulator as shown in Figure 1 and Figure 2. The shunt windings in the cutout relay and the current-voltage regulator unit are shown in dashed red. The charging circuit series windings are shown in solid red. The field circuit series winding is shown in blue. (Note—Two-brush shunt generators are also used.)

ator. The relay has two windings assembled on one core, a series winding of a few turns of heavy wire (shown in solid red) and a shunt winding of many turns of fine wire (shown in dashed red). The shunt winding is connected across the generator so that generator voltage is impressed upon it at all times. The series winding is connected in series with the charging circuit so that generator output passes through it.

The relay core and windings are assembled into a frame. A flat steel armature is attached to the frame by a flexible hinge so that it is centered just above the end of the core. The armature has one contact point which is located just above a similar stationary contact point. When the generator is not operating, the armature contact point is held away from the stationary contact point by the tension of a flat spring riveted on the side of the armature. When the generator operates the relay responds as described under Cutout Relay Action.

#### CURRENT-VOLTAGE REGULATOR

The combination current-voltage regulator is a device which provides control of the generator output and circuit voltage so as to meet various battery and operating requirements. The regulator has three windings assembled on one core, a series winding of a few turns of heavy wire (shown in solid red), a shunt winding of many turns of fine wire (shown in dashed red), and a series winding of a few turns of relatively heavy wire (shown in solid blue). The heavy series winding (solid red) is connected in series with the charging circuit, the shunt winding (dashed red) is connected

across the generator so that generator voltage is impressed on it at all times, the series winding of fairly heavy wire (solid blue) is connected in series with the generator field circuit when the regulator contact points are closed.

The windings and core are assembled into a frame. A flat, L-shaped, steel armature is attached to the frame by a flexible hinge so that it is just above the end of the core. The armature contains a contact point which is just beneath a stationary contact point. When the voltage regulator is not operating, spring tension holds the armature away from the core so that the points are in contact and the generator field circuit is completed to ground through them. (When the contact points are open, the field circuit is completed to ground through a separate wire-wound resistor beneath the regulator base. See Figure 3.)

#### OPERATION

In order to appreciate the function of the combined current-voltage type regulator, some attention must be given to the kind of service for which it is designed. On farm tractors and in some kinds of stationary service, the equipment is often operated for periods of days or weeks at a time with no electrical load other than occasional cranking. When such service occurs during hot weather or in installations where battery ventilation is poor, overheating of the battery may lead to serious overcharging by allowing the charge rate to increase. To prevent the charge rate from becoming unduly high under such conditions, the regulator must be able to control the current flowing to the battery at all times.

## STANDARD REGULATORS

On first consideration, it seems that a standard type regulator could be used, provided it were set to function at a suitably low voltage. Actually, such a regulator would be unsatisfactory since the low voltage settings would result in insufficient charge to the battery during cool or cold weather operation when battery counter voltage is naturally higher. This condition is more pronounced with tractor batteries because their location usually allows them to become colder and also prevents them from being warmed by engine heat as most automobile batteries are. On the other hand, if the voltage setting were increased sufficiently to satisfactorily charge the battery in cool weather, the new setting would be too high to prevent serious overcharging when the battery became hot. Here, again, the tractor battery is likely to reach higher operating temperatures than an automobile battery because of longer periods of continuous operation in hot weather. Furthermore, the standard current regulator unit serves only to limit maximum output of the generator and is ineffective in preventing overcharging at lower rates.

The combination current-voltage regulator overcomes these objections by controlling both the battery charge rate and the circuit voltage at the same time so as to prevent battery overcharge in hot weather and still provide a satisfactory charging rate to the battery during cold weather.

## CUTOUT RELAY ACTION

When the generator voltage builds up to a value great enough to charge the battery, the magnetism induced by the relay shunt winding is sufficient to overcome the armature spring tension and pull the armature toward the core so that the contact points close. This completes the circuit between the generator and battery. The current which flows from the generator to the battery passes through the series winding in the proper direction to add to the magnetism holding the armature down and the contact points closed.

When the generator slows down or stops, current begins to flow from the battery to the generator. This reverses the direction that the current flows through the series winding, thus causing a reversal of the magnetic field of the series winding. The magnetic field of the shunt winding does not reverse. Therefore, instead of helping each other, the two windings now magnetically oppose so that the resultant magnetic field becomes too weak to hold the armature down. The flat spring pulls the armature away from the core so that the points separate; this opens the circuit between the generator and battery.

## CURRENT-VOLTAGE REGULATOR ACTION

The combination current-voltage regulator action depends on both the current flowing through the heavy series (load) winding and the voltage imposed on the shunt winding. The field current winding also has some effect on the action as will be explained later.

When the generator goes into operation, the voltage imposed on the shunt winding causes some current to flow thus creating a magnetic field. Closing of the cutout relay allows current to flow through the load winding creating an additional magnetic field. When these two magnetic fields add up to sufficient strength, they pull the regulator armature toward the core causing the contact points to open. This diverts the field current to ground through the wire-wound resistor. The additional resistance of this circuit causes the generator voltage and output to drop. This, in turn, causes a weakening of the combined magnetic field from the load and shunt windings, so that the armature spring tension pulls the armature away from the core and the contact points close. Generator voltage and output then immediately increase, strengthening the magnetic field and causing the points to open again. This cycle is rapidly and continuously repeated as long as the generator and regulator are in operation, thus accomplishing the required control of the generator voltage and output.

The field current winding, already mentioned, might be termed an accelerator winding that speeds the action of the regulator armature in closing and opening the points. When the contact points are closed, the field current flows through the winding creating a small magnetic field. The strength of this field adds to the magnetic field strength of the shunt winding and helps to attract the armature. As the points open, current stops flowing through the field current winding, and its magnetic field collapses. Since this causes an appreciable weakening of the total magnetic field holding the points open, armature spring tension causes the points to close quickly. The result is that the rate of armature vibration is increased.

Since the electrical resistance of the regulator windings is lower when they are cold than when they are thoroughly warmed up, the voltage required to force a given current through the windings also varies. This condition would cause the regulator to operate at a considerably higher voltage when hot than when cold if the regulator were not compensated for temperature. Therefore, the current-voltage regulator includes a temperature compensating device in the form of a bi-metal hinge on the regulator armature. The action



## STANDARD REGULATORS

of this hinge provides increased spring tension when the regulator is cold and reduced spring tension when warm, thus offsetting the effect of changes in the electrical resistance of the windings with temperature.

**NOTE:** For the first few minutes of regulator operation, during which the regulator warms up, the temperature compensation does not produce a uniform decrease in the charging rate or voltage. The voltage may go up slightly and then begin to decrease. This is due to the fact that the internal regulator parts heat up at different rates—approximately 15 minutes being required for the internal parts to reach a stable operating temperature so that stable voltage and current readings can be obtained.

It is important to note that the combined current-voltage regulator characteristically functions so that the regulated voltage is reduced as the charge rate increases. That is, the higher the current to the battery, the lower the regulated voltage and vice versa. On a given 6-volt unit, for example, a charge rate of 3 amperes is accompanied by a regulated voltage of 7.2 volts, but with a charge rate of 6 amperes the regulated voltage is only 6.6 volts.

### REGULATOR ACTION WITH LOAD

With an electrical load, such as lights, turned on, the generator output increases. As shown in Figure 3, the regulator has an extra terminal marked "L" which is connected with the lower contact point in the cutout relay. This extra terminal permits current from the generator to be diverted to the load without its passing through the current-voltage regulator. This current has no reducing effect on the operating voltage since the regulator is affected only by current going to or from the battery. Generator output, therefore, is allowed to increase to a value sufficient to handle the load and still supply a charging current to the battery, provided, of course, that the total current requirements do not exceed the maximum output of the generator as determined by third brush setting and speed. In the case of shunt generators the maximum output is controlled by generator speed.

**NOTE:** Do not operate a shunt generator above the maximum speed encountered on the engine. When the generator is not in operation, the electrical load is supplied with current from the battery. The current, in this case, flows through the regulator load winding and the "L" terminal to the load.

### IMPORTANT

Lights, ignition (if battery ignition is used), and all other similar loads must be attached to the

"L" or load terminal of the current-voltage regulator and will not interfere with regulation. Any load (such as a horn), however, which may individually exceed the total output of the generator, must be connected direct to the battery side of the ammeter. Heavy currents cannot be drawn from the battery through the series winding of the current-voltage regulator without considerable increase in operating voltage.

Care must be taken to prevent interchanging the leads at the "L" or load terminal and the "BATTERY" terminal of the regulator. Loads, such as lights, connected to the "BATTERY" terminal of the regulator will prevent proper operation. Only the battery should be connected to the "BATTERY" terminal of the combined current-voltage regulator (except for horns and similar loads as already described).

### EMERGENCY WINTER OPERATION

During winter operation, if rundown batteries are repeatedly experienced and the condition is found to be due to short or infrequent engine operation, it is advisable to increase temporarily the operating voltage of the regulator.

A simple method of increasing voltage is to disconnect the lead to regulator "BAT" terminal and reconnect this lead to the regulator "L" terminal. The reconnection by-passes the current-voltage feature of the regulator, automatically allowing an increase in the operating voltage and increasing the amount of charge to the battery.

**CAUTION:** Operate the regulator with these connections only during cold weather and when operating periods are short or infrequent. Re-establish the original lead connections as soon as mild weather returns, or operation time becomes normal, otherwise the battery will be damaged by overcharge.

### REGULATOR POLARITY

Some regulators are designed for use with negative grounded batteries while other regulators are designed for use with positive grounded batteries. Using the wrong polarity regulator on an installation will cause the regulator contact points to deteriorate and give short life. Care must be used to avoid interchanging the two types in service.

## REGULATOR MAINTENANCE

### GENERAL INSTRUCTIONS

1. Electrical checks may be made either on or off the vehicle. The regulator must always be operated with the type generator for which it is designed.

## STANDARD REGULATORS

- 
2. The regulator must be mounted in the operating position when electrical settings are checked, and it must be stabilized at operating temperature.
  3. After any tests, the generator should be repolarized after leads are reconnected but before the engine is started, as follows:

**POLARIZING GENERATOR**

After reconnecting leads, momentarily connect a jumper lead between the "BATTERY" terminal of regulator and "ARMATURE" terminal of generator. This allows a momentary surge of current to flow through the generator which correctly polarizes it. Reversed polarity may result in vibration, arcing, and burning of the relay contact points.

**QUICK CHECKS OF GENERATOR AND REGULATOR**

In analyzing complaints of generator-regulator operation, any of several basic conditions may be found.

(1) **Battery Remains Charged with Low Water Usage**—This indicates normal generator-regulator operation. Regulator settings may be checked as outlined in the following sections.

(2) **Battery Remains Charged with High Water Usage**—If the electrolyte level in the battery drops to the tops of the separators in less than 100 hours of normal operation, it indicates that the current-voltage regulator is not reducing the current flowing to the battery as it should. Excessive current flowing to a fully charged battery will cause serious damage in the battery. This operating condition may result from:

- (a) Improper setting of the current-voltage regulator unit.
- (b) Defective current-voltage regulator unit.
- (c) Grounded generator field circuit (in either generator, regulator, or wiring).
- (d) The load and battery leads may be interchanged at the regulator terminals.

To determine the cause of trouble, first disconnect the lead from the regulator "F" terminal with the generator operating at medium speed. If the output remains high, the generator field is grounded either in the generator (see Service Bulletin 1G-150) or in the wiring harness. If the generator output stops, the regulator is probably at fault, and it should be checked for high current-voltage setting. To check the possibility of interchanged leads at the "L" and "B" terminals, reconnect field lead at regulator and then with generator operating at approximately 2500 r.p.m., turn on lights. With lights on, disconnect lead at "L" terminal.

If lights go out, leads are properly connected. If lights stay on, leads are interchanged at "L" and "B" terminals of regulator and must be corrected.

(3) **Battery Remains Low or Discharged**—This condition could be due to:

- (a) Loose connections, frayed or damaged wires.
- (b) Defective battery. (Battery should take charge and should crank engine.)
- (c) High circuit resistance. (Check voltage drop between "BAT" terminal of regulator and battery. Drop should not exceed 0.15 volts with 3-4 amperes flowing.)
- (d) Low regulator setting.
- (e) Damage or defects within the regulator.
- (f) Defects within the generator.
- (g) Continuous loads in excess of generator capacity.

If the condition is not caused by loose connections, frayed, or damaged wires, defective battery, high circuit resistance, or excessive loads, the trouble will be found in the generator or regulator. To determine which is at fault proceed as follows:

If Generator Shows Some Output—With generator operating at medium speed, a charge rate of 1 to 3 amperes is normal with fully charged battery at normal operating temperatures. If battery is in a discharged condition or is extremely hot, charge rate will be considerably higher. If condition of battery indicates that charge rate is too low, momentarily ground "FIELD" terminal of regulator. If output shows a strong increase, trouble is probably due to low setting of current-voltage regulator unit or to dirty contact points in regulator. If output does not increase, generator is probably at fault and should be checked as outlined in Service Bulletin 1G-150.

If Generator Shows No Output—With generator operating at medium speed, momentarily connect a jumper between "GENERATOR" and "BATTERY" terminals of regulator. If generator shows output, the relay is at fault. If generator does not show output, momentarily ground "FIELD" terminal of generator. If generator now shows output, regulator is at fault. If generator still does not show output, the generator is at fault and should be checked as outlined in Service Bulletin 1G-150.

(4) **Damaged Resistor**—If the resistor attached beneath the regulator is broken or otherwise damaged, the contact points of the current-voltage regulator unit soon become burned. This condition results in a low generator output. Whenever a resistor is replaced it will usually be found necessary to clean the contact points in order to restore satisfactory operation.



## STANDARD REGULATORS

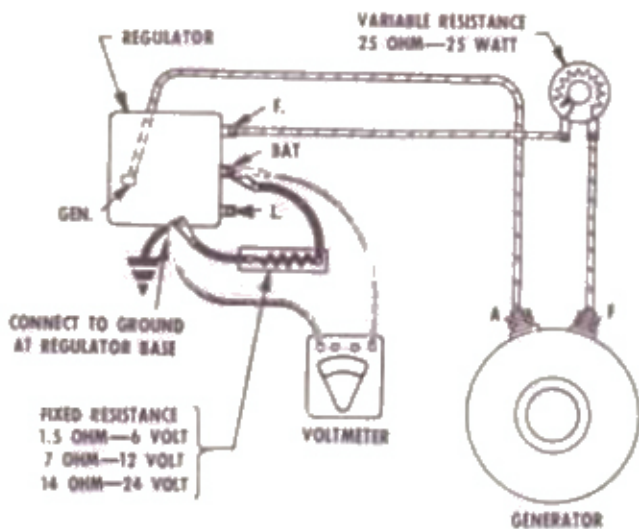

Figure 4—Fixed resistance, variable resistance, and voltmeter connections for checking current-voltage regulator unit electrical setting. Fixed resistance leads in red, and voltmeter leads in blue.

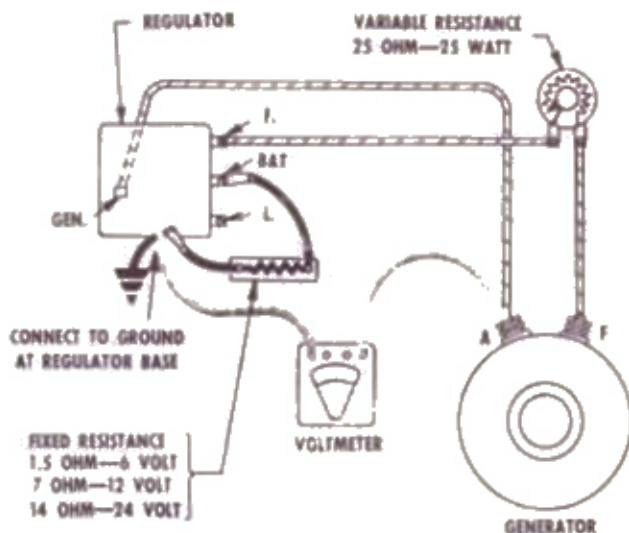

Figure 5—Fixed resistance, variable resistance, and voltmeter connections for checking cutout relay closing voltage. Fixed resistance leads in red and voltmeter leads in blue.

(5) Damage Within the Regulator—This may be due to reversed generator polarity. Generator polarity must be corrected as explained in POLARIZING GENERATOR after any checks of the regulator or generator, or after disconnecting and reconnecting leads.

### REGULATOR ELECTRICAL CHECKS

(See Delco-Remy Service Bulletins 1R-180, 1R-185, and 1R-186 for specifications.)

The electrical settings of the cutout relay and the current-voltage regulator unit may be checked either on or off the installation without removing the regulator cover. When bench checks are made, the regulator must be connected only to a generator of the type for which it is designed. Results obtained with any other type of generator will be meaningless. When the regulator is checked on the installation, all loads (including ignition) connected to the "L" terminal must be switched off. To furnish ignition current during tests for electrical settings, use a jumper lead to connect free end of battery lead direct to primary terminal of ignition coil (switch side).

### CURRENT-VOLTAGE REGULATOR UNIT SETTING

To check the electrical setting of the current-voltage regulator unit, disconnect the lead from the "BATTERY" terminal of the regulator, and connect a fixed resistor from the "BATTERY"

terminal of the regulator to "GROUND" on the regulator base (Fig. 4). Use a 1.5-ohm\* resistor for a 6-volt system, a 7-ohm resistor for a 12-volt system, and a 14-ohm resistor for 24-volt system.

\*A 1.5-ohm resistor is required for a 6-volt unit of this type because its operating characteristics are different from those of standard regulators.

Disconnect the lead from the "FIELD" terminal of the regulator, and connect a variable resistance (25-ohm—25-watt) in series between the lead and the "FIELD" terminal. The variable resistance must have an "open" position at the extreme left end of its travel (Fig. 4). Connect a low reading test voltmeter between the "BATTERY" terminal of the regulator and "GROUND" at the base of the regulator. For this check the regulator must be stabilized at operating temperature, otherwise the results are of no value. To stabilize the regulator, operate the generator at a speed of 2500 r.p.m. for at least 15 minutes with the fixed resistor connected and the knob of the variable resistance turned to the right so that the resistance is entirely cut out. With the generator operating at 2500 r.p.m. and all electrical load (including ignition) disconnected from the "L" terminal of the regulator, slowly turn the operating knob of the variable resistance to the left until the circuit is broken at the "open" position. Then turn the knob back to the right slowly until the resistance is entirely cut out. Note the voltage setting. If the check is repeated, the knob on the variable resistance must be turned to the "open" position each time before the voltage is again raised.

## STANDARD REGULATORS

## CUTOUT RELAY CLOSING VOLTAGE CHECK

The cutout relay closing voltage check should be made immediately after the current-voltage regulator unit check while the regulator is stabilized at operating temperature. Electrical connections for this test are exactly like those for the current-voltage unit check except that the voltmeter is connected from the "A" terminal of the generator to "GROUND" as shown in Figure 5.

To check the cutout relay closing voltage, turn the knob of the variable resistance to the right until the resistance is entirely cut out, and start

the generator. Adjust the generator speed to approximately 2500 r.p.m. Slowly turn the knob of the variable resistance to the left until the "open" position is reached and the field circuit is broken. Then turn the knob slowly to the right so that the generator voltage rises slowly until the relay closes. (Closing of the relay is indicated by a sharp drop in voltage.) Note the closing voltage. If the check is repeated, the knob on the variable resistance must be turned to the "open" position each time (so that the field circuit is broken) before raising the voltage to the closing point of the relay. This is necessary to eliminate the effects of residual magnetism.

## REGULATOR CHECKS AND ADJUSTMENTS

(See Delco-Remy Service Bulletins 1R-180, 1R-185, and 1R-186 for Specifications.)

## CLEANING CONTACT POINTS

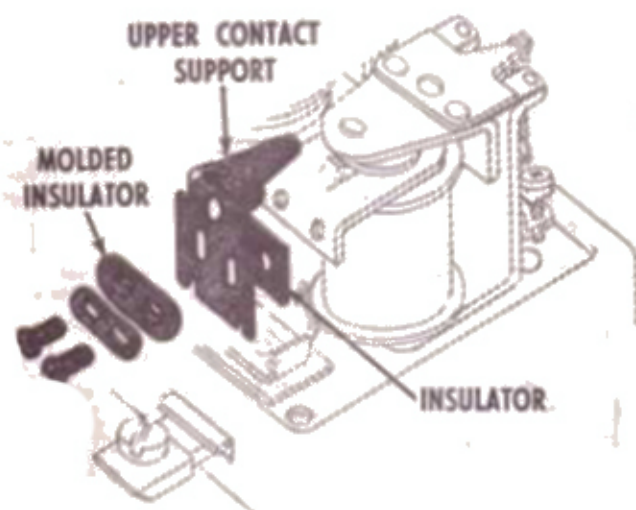

Figure 6—Disassembly of upper contact support for cleaning or replacement.

In many cases regulator trouble can be eliminated by a simple cleaning of the contact points, plus some possible readjustment. The flat points should be cleaned with a spoon or riffler file. On positive grounded regulators, the flat point is in the upper contact bracket so the bracket must be removed for cleaning the points (Fig. 6). A flat file cannot be used successfully to clean the flat contact points since it will not touch the center of the flat point where point wear is most likely to occur. **NEVER USE EMERY CLOTH OR SANDPAPER TO CLEAN THE CONTACT POINTS.**

## CUTOUT RELAY CHECKS AND ADJUSTMENTS

The cutout relay requires three checks and adjustments: air gap, point opening, and closing voltage. The air gap and point opening adjustments are made with the battery disconnected.

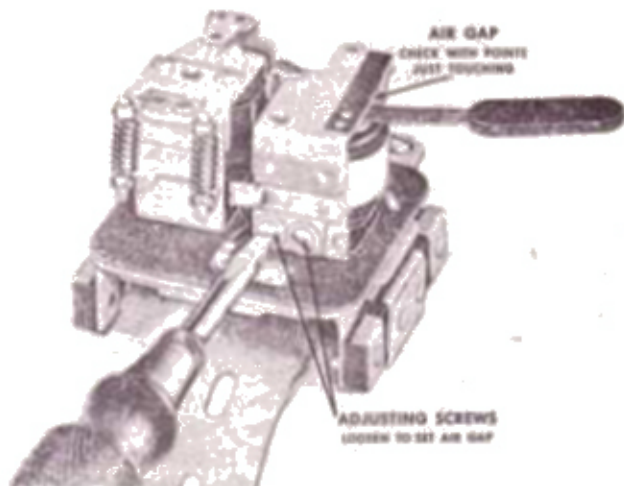

Figure 7—Cutout relay air gap check and adjustment (1118200 series). Battery must be disconnected when this check is made.

**AIR GAP (1118200 Series)**—Place fingers on armature directly above core and move armature down until points just close, and then measure air gap between armature and center of core (Fig. 7). To adjust air gap, loosen two screws at back of relay and raise or lower armature as required. Tighten screws after adjustment.

## STANDARD REGULATORS

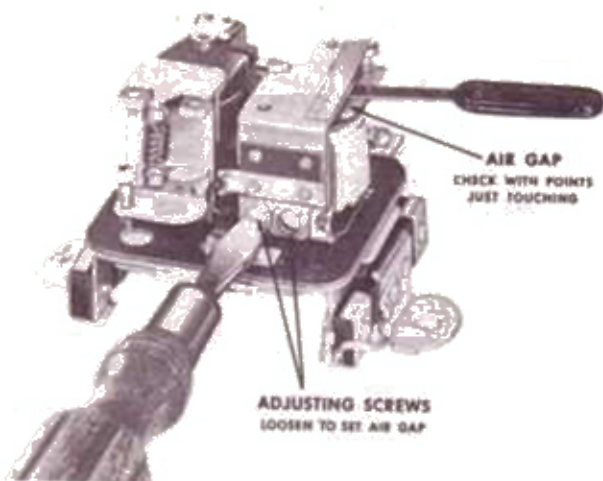

Figure 8—Cutout relay air gap check and adjustment (1118300 and 1118700 series). Battery must be disconnected when this check is made.

**AIR GAP (1118300 and 1118700 Series)**—Check and adjust as in 1118200 Series (Fig. 8).

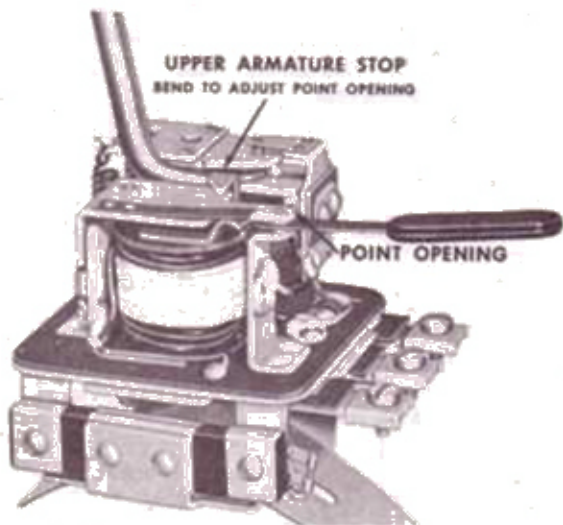

Figure 9—Cutout relay point opening check and adjustment (1118200 series). Battery must be disconnected when this check is made.

**POINT OPENING (1118200 Series)**—Check point opening and adjust by bending the upper armature stop (Fig. 9).

**POINT OPENING (1118300 and 1118700 Series)**—Check and adjust point opening as in 1118200 Series (Fig. 10).

**CLOSING VOLTAGE (1118200 Series)**—Check closing voltage as described under Regulator Electrical Checks. Adjust closing voltage by bending the armature spring post (Fig. 11). Bend up to in-

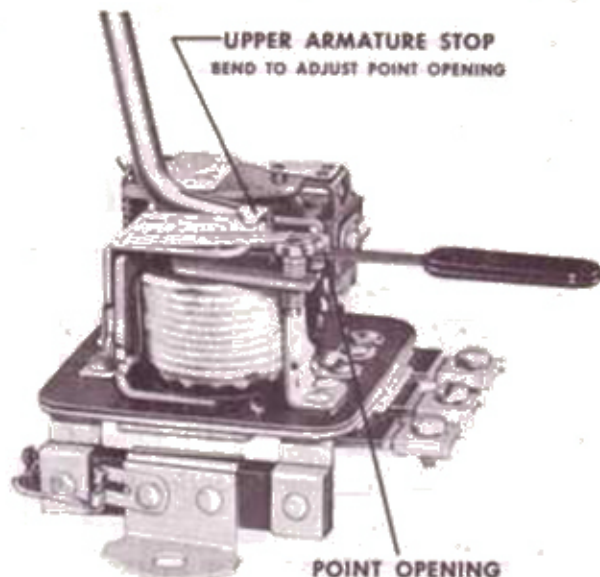

Figure 10—Cutout relay point opening check and adjustment (1118300 and 1118700 series). Battery must be disconnected when this check is made.

crease spring tension and closing voltage, and bend down to decrease closing voltage.

**CLOSING VOLTAGE (1118300 and 1118700 Series)**—Check closing voltage as described under Regulator Electrical Checks. Adjust closing voltage by turning adjusting screw (Fig. 12). Turn screw clockwise to increase spring tension and closing voltage, and turn counterclockwise to decrease closing voltage.

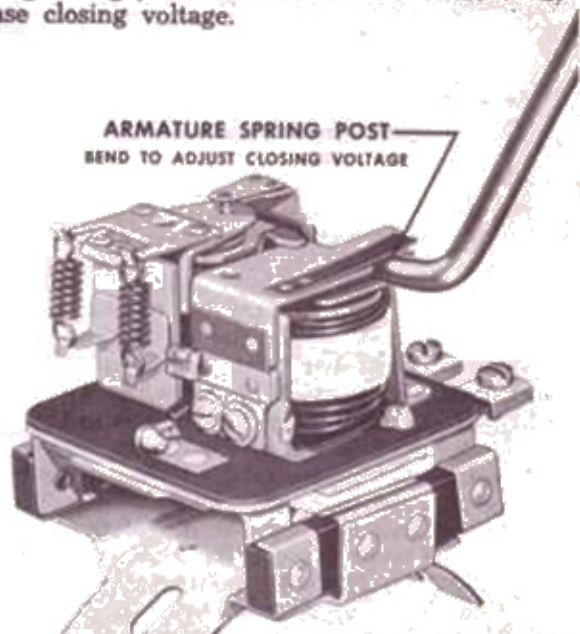

Figure 11—Adjustment of cutout relay closing voltage (1118200 series).



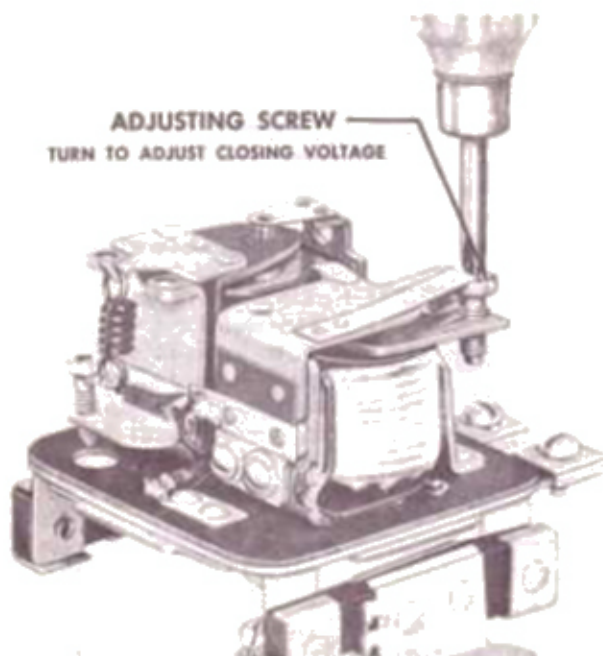

Figure 12—Adjustment of cutout relay closing voltage (1118300 and 1118700 series).

### CURRENT-VOLTAGE UNIT CHECKS AND ADJUSTMENTS

The current-voltage unit requires two checks and adjustments, air gap and voltage setting.

**AIR GAP (1118200 Series)**—To check air gap, push armature down until the contact points are just touching, and then measure air gap (Fig. 13). Adjust by loosening contact mounting screws and raising or lowering contact bracket as required. Be sure points are lined up, and tighten screws after adjustment.

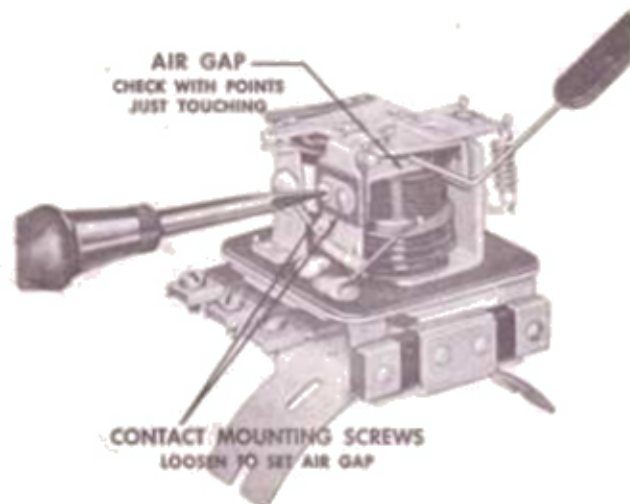

Figure 13—Current-voltage unit air gap check and adjustment (1118200 series).

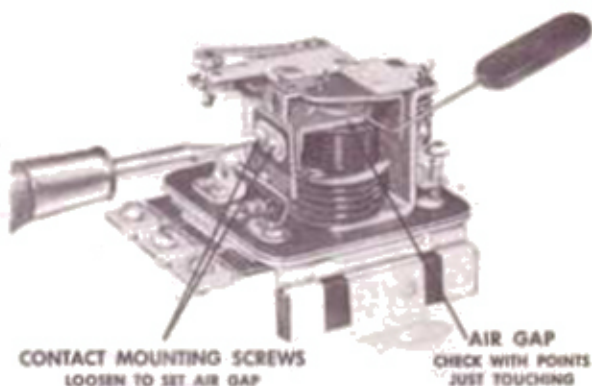

Figure 14—Current-voltage unit air gap check and adjustment (1118300 and 1118700 series).

**AIR GAP (1118300 and 1118700 Series)**—Check and adjust air gap as in 1118200 Series (Fig. 14).

**VOLTAGE SETTING (1118200 Series)**—Check voltage setting as described under Regulator Electrical Checks. Adjust by bending the lower spring hanger of one spring (Fig. 15). Bend down to increase the voltage setting, or bend up to lower the setting. After each adjustment, set cover in place before checking setting. Confine adjustment to one spring only. If the unit is badly out of adjustment, refer to section headed Regulator Spring Replacement.

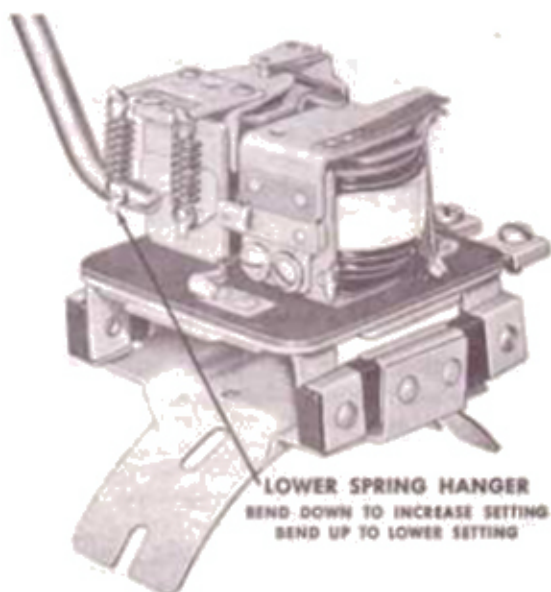

Figure 15—Adjusting voltage setting of current-voltage regulator unit (1118200 series).



## STANDARD REGULATORS

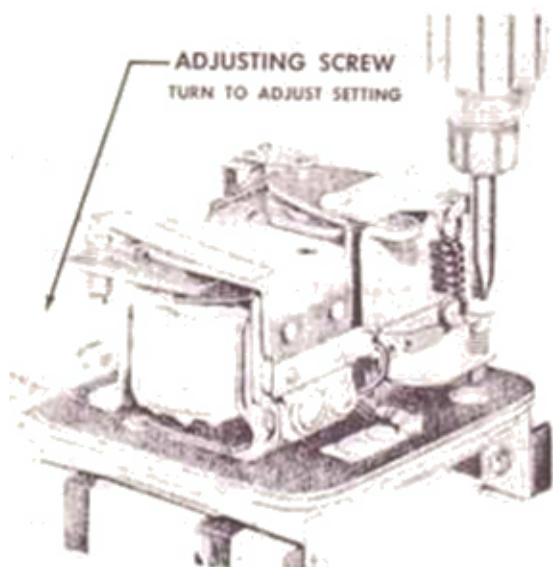

Figure 16—Adjusting voltage setting of current-voltage regulator unit (1118300 and 1118700 series).

**VOLTAGE SETTING** (1118300 and 1118700 Series)—Check voltage setting as described under Regulator Electrical Checks. Adjust voltage setting by turning adjusting screw (Fig. 16). Turn screw clockwise to increase voltage setting and counterclockwise to decrease voltage setting. After each adjustment, set cover in place before checking setting.

### CAUTION

If adjusting screw is turned down (clockwise) beyond normal range required for adjustment, spring support may fail to return when pressure is relieved. In such an instance, turn screw counterclockwise until sufficient clearance develops between screw head and spring support, then bend spring support upward carefully with small pliers until contact is made with screw head. Final setting of unit should always be approached by increasing spring tension, never by reducing it. In other words, if setting is found to be too high,

## HIGH POINTS ON REGULATOR PERFORMANCE AND CHECKS

1. The current-voltage unit by its action protects the distributor points, lights, and other accessories from high voltage, and prevents excessive charge rates to a fully charged battery.
2. The proper testing equipment in the hands of a qualified mechanic is necessary to assure proper and accurate regulator settings. Any attempt on the part of untrained personnel to adjust regulators is likely to lead to serious damage to the electrical equipment and should be discouraged.
3. Never set the regulator outside specified limits.
4. Always make sure that the rubber gasket is in

unit should be adjusted below required value and then raised to exact setting by increasing spring tension. *Be sure screw is exerting force on hanger.*

### REGULATOR SPRING REPLACEMENT

When the current-voltage unit is badly out of adjustment or requires spring replacement, the following procedures must be followed.

**CURRENT-VOLTAGE Unit (1118200 Series)**—Make connections as in Figure 5 for Cutout Relay Closing Voltage Check. Turn knob of variable resistance completely to right to cut out all resistance. Install one spring on current-voltage unit. Open contact points on current-voltage unit by hand. Start generator and slowly raise speed to approximately 2500 r.p.m. Maintain this speed, release armature and adjust spring hanger until voltmeter reads 4.0-4.5 volts (8.0-9.0 volts on 12 volt system). Install second spring, reconnect voltmeter as in Figure 4 and complete voltage adjustment on second spring as described under Voltage Setting of Current-Voltage Unit.

**CURRENT-VOLTAGE Unit (1118300 and 1118700 Series)**—When installing a new spring on units of this type, care must be taken to avoid bending or distorting spring supports or armature hinge. Spring should preferably be hooked at the lower end first and then stretched upward by means of a screw driver blade inserted between the turns, or by the use of any other suitable tool, until upper end of spring can be hooked. Do not try to pry upper end of spring over spring support. Make connections as in Figure 4 and adjust as described under Voltage Setting of Current-Voltage Unit.

### REPLACING CONTACT SUPPORT BRACKET

The current-voltage unit contact support bracket can be replaced by following the relationship illustrated in Figure 6.

- place and compressed when replacing cover. The gasket prevents entrance of moisture, dust, and oil vapors which might damage the regulator.
5. Many of the regulators are designed to be used with a positive grounded battery only, while others are designed to be used with a negative grounded battery only. Never attempt to use the wrong polarity regulator on an application.
6. After any generator or regulator tests or adjustments, the generator should be polarized as explained on page 5 to avoid damage to the equipment.